

MOTION CONTROL AT ITS CORE



Juno[®] top Control IC

South

for up

User Guide





NOTICE

This document contains proprietary and confidential information of Performance Motion Devices, Inc., and is protected by federal copyright law. The contents of this document may not be disclosed to third parties, translated, copied, or duplicated in any form, in whole or in part, without the express written permission of PMD.

The information contained in this document is subject to change without notice. No part of this document may be reproduced or transmitted in any form, by any means, electronic or mechanical, for any purpose, without the express written permission of PMD.

Copyright 1998–2017 by Performance Motion Devices, Inc.

Juno, ATLAS, Magellan, ION, Magellan/ION, Pro-Motion, C-Motion, and VB-Motion are trademarks of Performance Motion Devices, Inc.

Warranty

PMD warrants that its products shall substantially comply with the specifications applicable at the time of sale, provided that this warranty does not extend to any use of any PMD product in an Unauthorized Application (as defined below). Except as specifically provided in this paragraph, each PMD product is provided “as is” and without warranty of any type, including without limitation implied warranties of merchantability and fitness for any particular purpose.

PMD reserves the right to modify its products, and to discontinue any product or service, without notice and advises customers to obtain the latest version of relevant information (including without limitation product specifications) before placing orders to verify the performance capabilities of the products being purchased. All products are sold subject to the terms and conditions of sale supplied at the time of order acknowledgment, including those pertaining to warranty, patent infringement and limitation of liability.

Unauthorized Applications

PMD products are not designed, approved or warranted for use in any application where failure of the PMD product could result in death, personal injury or significant property or environmental damage (each, an “Unauthorized Application”). By way of example and not limitation, a life support system, an aircraft control system and a motor vehicle control system would all be considered “Unauthorized Applications” and use of a PMD product in such a system would not be warranted or approved by PMD.

By using any PMD product in connection with an Unauthorized Application, the customer agrees to defend, indemnify and hold harmless PMD, its officers, directors, employees and agents, from and against any and all claims, losses, liabilities, damages, costs and expenses, including without limitation reasonable attorneys’ fees, (collectively, “Damages”) arising out of or relating to such use, including without limitation any Damages arising out of the failure of the PMD product to conform to specifications.

In order to minimize risks associated with the customer’s applications, adequate design and operating safeguards must be provided by the customer to minimize inherent procedural hazards.

Disclaimer

PMD assumes no liability for applications assistance or customer product design. PMD does not warrant or represent that any license, either express or implied, is granted under any patent right, copyright, mask work right, or other intellectual property right of PMD covering or relating to any combination, machine, or process in which such products or services might be or are used. PMD’s publication of information regarding any third party’s products or services does not constitute PMD’s approval, warranty or endorsement thereof.

Related Documents

Juno Velocity & Torque Control IC User's Guide

Complete description of the Juno Velocity & Torque Control IC features and functions with detailed theory of operations.

Juno Velocity & Torque Control IC Command Reference

Description of all Juno family IC commands, with coding syntax and examples, listed alphabetically for quick reference.

MC78113 Electrical Specifications

Complete electrical specifications for MC78113 ICs containing physical and electrical characteristics, timing diagrams, pinouts, and pin descriptions.

MC78113 Developer's Kit Users Manual

How to install and configure the DK78113 Developer's Kit

Pro-Motion User's Guide

User's guide to Pro-Motion, the easy-to-use motion system development tool and performance optimizer. Pro-Motion is a sophisticated, easy-to-use program which allows all motion parameters to be set and/or viewed, and allows all features to be exercised.

Table of Contents

1. Installation	9
1.1 Introduction	9
1.2 Developer's Kit Components List	10
1.3 DK78113 Card	10
1.4 Software	10
1.5 Included Hardware Accessories	11
1.6 Installation Overview	12
1.7 Recommended Hardware	12
1.8 Software Installation	13
1.9 Preparing the Card for Installation	13
1.10 Connection Summary	15
1.11 Applying Power	18
1.12 First-Time System Verification	18
2. Operation	25
2.1 DK78113 Block Diagram	25
2.2 Communication Ports	26
2.3 Switching Motor Amplifier	28
2.4 Drive Protection and Control Signals	33
2.5 DC Bus	35
2.6 Connecting to a Remote Amplifier	37
2.7 Miscellaneous Signal Processing	38
2.8 Pulse, Direction, & AtRest	39
2.9 Analog Command & Tachometer Inputs	40
2.10 Enable & FaultOut	41
2.11 On-IC NVRAM Configuration Storage	42
3. Electrical Reference	43
3.1 User-Settable Components	43
3.2 Connectors	44
3.3 Motor Connection Quick Reference	49
3.4 Absolute Maximum Ratings	50
3.5 Environmental and Electrical Ratings	50
3.6 DK78113 On-Card Amplifier Quick Reference	50

This page intentionally left blank.

List of Figures

1-1	DK78113 Card Components Location	14
1-2	Brushless DC Motor Connection Overview	15
1-3	DC Brush Motor Connection Overview	16
1-4	Step Motor Connection Overview	16
2-1	DK78113 Block Diagram	26
2-2	PC to DK78113 SPI Connection Summary	27
2-3	SPI Signal Circuitry	28
2-4	Brushless DC Motor Bridge Configuration	29
2-5	DC Brush Motor Bridge Configuration	30
2-6	Two-Phase Step Motor Bridge Configuration	31
2-7	DC Bus Monitoring Circuitry	35
2-8	DK78113 to Remote Amplifier Card Connections	37
2-9	Remote Switcher Circuits	38
2-10	Main Encoder Input Circuits	39
2-11	Hall Input Circuits	39
2-12	Pulse, Direction, & AtRest	40
2-13	Analog Command & Tachometer Inputs	40
2-14	Enable Input Circuit	41
2-15	FaultOut Circuit	41
3-1	DK78113 Card Component Location	44

This page intentionally left blank.

1. Installation

In This Chapter

- ▶ Introduction
- ▶ Developer's Kit Components List
- ▶ DK78113 Card
- ▶ Software
- ▶ Included Hardware Accessories
- ▶ Installation Overview
- ▶ Recommended Hardware
- ▶ Software Installation
- ▶ Preparing the Card for Installation
- ▶ Connection Summary
- ▶ Applying Power
- ▶ First-Time System Verification

1.1 Introduction

The PMD MC78113 Developer's Kit is an integrated board/software package that serves as an electrical and software design tool for building systems that use Juno MC78113 family ICs.

The developer's kit supports all five members of the MC78113 IC family, as shown below:

Developer's Kit p/n	Installed IC	Motors Supported
DK78113	MC78113	DC Brush, Brushless DC, step motor
DK71113	MC71113	DC Brush
DK73113	MC73113	Brushless DC
DK74113	MC74113	Step motor with encoder
DK75113	MC75113	Step motor

All of the above Developer's Kit versions share the same physical DK78113 card as well as the same software CD. They differ in the specific type of MC78113 family IC chip that is installed in the card.

Note that throughout this manual the term MC78113 may be used to mean all members of the MC78113 family including the MC78113, MC71113, MC73113, MC74113, and MC75113 ICs. Similarly, in this manual the term DK78113 may be used to mean to all versions of the DKs from the table above including the DK78113, DK71113, DK73113, DK74113, and DK75113 developer kits.



1.2 Developer's Kit Components List

The MC78113 Velocity & Torque Control IC Developer's Kit contains the following components:

- DK78113 Developer's Kit card
- Cable sets and pin breakout mini-card for various card connectors
- Magellan SDK CD-ROM containing C-Motion and documentation in PDF format
- Pro-Motion CD-ROM

Documentation:

- *MC78113 Developer's Kit User's Manual*
- *Juno Velocity & Torque Control IC User's Guide*
- *Juno Velocity & Torque Control IC Command Reference*
- *MC78113 Electrical Specifications*
- *Pro-Motion User's Guide*

If any of these components are missing, please contact your PMD representative.

1.3 DK78113 Card

The heart of the MC78113 Velocity & Torque Control IC Developer's Kit is the DK78113 printed circuit card that contains interface and amplifier circuitry to allow various features of the MC78113-family ICs to be accessed. Here is a summary of the features provided by the DK78113 card:

- Supports step, DC Brush, and Brushless DC motors
- IC socket allows MC78113s to be swapped out for testing or user configuration storage
- High performance on-card amplifier with current feedback supports all motor types
- Interfaces to external user-designed amplifier
- RS-232, RS-485, CANbus, and SPI (Serial Peripheral Interface) host communications
- Single DC-voltage supply
- Quadrature signal input with Index capture
- Hall sensor input
- Support for overtemperature, overcurrent, over and undervoltage sense
- High current external shunt resistor support
- Pulse & Direction input with *AtRest* signal support
- Compact 3.2" x 4.1" standalone form factor (8.1 cm x 10.4 cm)

1.4 Software

Three major software packages are provided with the DK78113:

Pro-Motion®, an interactive Windows-based exerciser & software development tool

C-Motion®, a C-language library that allows you to create motion applications using the C programming language

Here is more information on each of these software packages:

1.4.1 Pro-Motion

Pro-Motion is a sophisticated, easy-to-use exerciser program which allows all MC78113 parameters to be set and/or viewed, and allows all features to be exercised. Pro-Motion features include:

- Motion oscilloscope graphically displays processor parameters in real-time
- AxisWizard to automate axis setup and configuration
- Current loop auto-tuning
- Project window for accessing motion resources and connections
- Ability to save and load settings
- Distance, time, and electrical units conversion
- Frequency sweep and bode plot analysis tools
- Motor-specific parameter setup

Pro-Motion is described in the *Pro-Motion User's Guide*.

1.4.2 C-Motion

C-Motion provides a convenient set of callable routines comprising the code required for controlling the Juno Velocity & Torque Control IC. C-Motion includes the following features:

- Magellan axis virtualization
- Ability to communicate to multiple PMD motion cards or modules
- Ability to communicate via serial, CANbus, or SPI (Serial Peripheral Interface)
- Provided as source code, allowing easy compilation & porting onto various run-time environments including PC, microprocessor, embedded card, or PMD's C-Motion Engine
- Can be easily linked to any C/C++ application

C-Motion is described in the *Juno Velocity & Torque Control IC Command Reference*.

1.5 Included Hardware Accessories

The DK78113 includes various accessories that you may find useful:

Component PMD Part Number	Description
Cable-1007-01	Serial cable. This cable connects to the DK78113's DB-9 serial port and provides a connection to a PC serial port or USB to serial converter.
Cable-4705-KIT-01.R	CANbus connector and terminator. This cable connects to the card's CANbus connector and has RJ45 connectors on both ends.

Component PMD Part Number	Description
MC-HW-05	DB-15 breakout interconnect. This module provides convenient jack-screw type terminators for the 15-pin axis connector.
Adapt-USB232-01.R	This adapter provides USB to serial conversion. It is useful for connecting to the DB-9 serial port from a USB port.
CONN-0122-11	Power & shunt connector jack screw terminals. This two-pin plug provides convenient jack-screw-type terminals for the high current terminal block header power & shunt resistor connectors. Two units are included.
CONN-0121-11	Motor connector jackscrew terminals. This five-pin plug provides convenient jack-screw-type terminals for the high current terminal block header motor connector.

If for whatever reason you need to order more of these accessories, refer to the part numbers above and contact your PMD representative.

1.6 Installation Overview

- 1 Before using the card, the software must be installed. See [Section 1.8, “Software Installation”](#) for instructions on installing the software.
- 2 For a normal installation of the DK78113 card you will need to configure the card. See [Section 1.9, “Preparing the Card for Installation”](#) for a description of configuring the card.
- 3 Next, connect the system’s motor, encoder, and sensors to operate the motion hardware. See [Section 1.10, “Connection Summary”](#) for a description of the available connections and options for the DK78113 card.
- 4 Connect the DK78113 card to the host PC via a Serial cable. See [Section 1.10.4, “Communication Connections”](#) for a description of this procedure.
- 5 Once this hardware configuration is complete, the final step to finish the installation is to perform a functional test of the finished system. See [Section 1.12, “First-Time System Verification”](#) for a description of this procedure.

Once these steps have been accomplished, the installation is complete, and the card is ready for operation.

1.7 Recommended Hardware

To install a DK78113 card the following hardware is recommended. Note that this list assumes that the on-card amplifier will be used, and that the motors are connected to allow velocity control. For installation of a user-provided off-card amplifier, see [Section 2.6, “Connecting to a Remote Amplifier”](#) for more information.

- Intel (or compatible) processor, 1 Gbyte of available disk space, 256 MB of available RAM, and a CD-ROM drive. The supported PC operating systems are Windows XP, Vista, Windows 7, Windows 8, Windows 10.
- One step, DC brush, or brushless DC motor.

This motor may or may not provide encoder position feedback signals, depending on the type of motor being used. Encoder feedback is normally used with DC brush motors and with brushless DC motors (although not required because Hall sensors can be used for the position feedback). For step motors, encoders are an option.

- Cables as required to connect to the motor and associated motion hardware such as feedback signals.

- Power supply, power cable, and communication cables.
- The DK78113 card requires only a single voltage supply. The card logic and other circuitry is powered from this input voltage using an on-card DC to DC converter. Although the DK78113 supports serial, CANbus and SPI communications, for first-time installation you will use the card's serial port.

1.8 Software Installation

Two CD-ROMs comprise the software distribution for the MC78113 developer's kit. All software applications are designed to work with Microsoft Windows.

- Pro-Motion: The Pro-Motion disk is located in its own Pro-Motion box, and contains the software associated with the Pro-Motion Optimized Motion System Development software.
- Magellan SDK: This disk contains the C-Motion source libraries, and VB-Motion Libraries.

To install the software:

- 1 Insert the Pro-Motion disk into the CD-ROM drive of your computer.
 - If autorun is enabled, the installation process will begin when the CD-ROM is inserted.
 - If autorun is not enabled, go to the next step.
- 2 On the Start menu, click Run.
- 3 In the Open text box, type D:\setup.exe.
where D: is the drive letter of your computer's CD-ROM drive.
- 4 Follow the on-screen prompts to complete the installation process.

Once installation of Pro-Motion is complete, insert the Magellan SDK disk, and follow the same procedure above as for Pro-Motion installation.

Upon completion of the installation process for Pro-Motion and SDK, the following components will be installed:

- Pro-Motion—an application for communicating to, and exercising the motion control IC. Refer to the *Pro-Motion User's Guide* for operating instructions.
- C-Motion—source code which may be used for developing motion applications in C/C++ based using the Juno Velocity & Torque Control IC.
- DLLs and example source code which may be used for developing motion applications in Visual Basic or C# based on the MC78113.
- PDF versions of the *MC78113 Developer's Kit User's Manual*, *MC78113 Electrical Specifications*, *Juno Velocity & Torque Control IC Command Reference*, and *Juno Velocity & Torque Control IC User's Guide*. Adobe Acrobat Reader is required for viewing these files. If the Adobe Acrobat Reader is not installed on your computer, it may be freely downloaded from <http://www.adobe.com>.

1.9 Preparing the Card for Installation

[Figure 1-1](#) shows the location of various on-card components such as connectors and jumpers.

**Figure 1-1:
DK78113 Card
Components
Location**

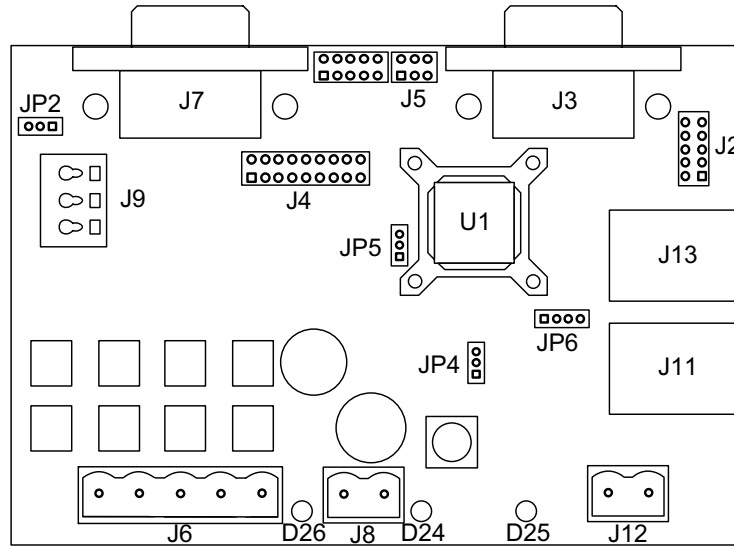

The following table describes these components:

Label	Description
J8	HV Power Connector
J6	Motor Drive Connector
J7	Feedback Connector
J9	Amplifier Signal Connector
J4	Remote Amplifier Connector
J5	Analog Command Connector
J12	Shunt Connector
J13, J11	CAN1, CAN2 Connectors (respectively)
J3	Serial Connector
J2	Host SPI Connector
D24, D25, D26	Power, fault, and amplifier enabled LED indicators (respectively)
JP2	SPI Mode jumper
JP4, JP5	Remote amplifier enable jumpers
JP6	RS-232/RS-485 selector jumper

There are no jumper changes that need to be made to the card. The DK78113 comes factory-configured to be compatible with the ‘first time installation’ instructions contained in this chapter.

However, for reference the table below shows the available jumper settings of the DK78113 card:

Jumper ID	Factory Default Setting	Setting & Description
JP2	1-2 (host communications)	1-2 Installing jumper at 1-2 for JP2 configures the SPI port for host communications utilizing the packet-based commands described in the <i>Juno Velocity & Torque Control IC Command Reference</i> .
JP2		2-3 Installing jumper at 2-3 for JP2 configures the SPI port for direct input velocity or torque commands.

Jumper ID	Factory Default Setting	Setting & Description
JP4, JP5	1-2 (on-card amplifier)	1-2 Installing jumpers at 1-2 for JP4 and JP5 configures the DK78113 for operation of the on-card amplifier.
		2-3 Installing jumpers at 2-3 for JP4 and JP5 disables the on-card amplifier, and configures the DK78113 for operation with a user-designed amplifier via the J4 Remote Amplifier Connector.
JP6	1-2 (RS-232)	1-2 Installing a jumper at 1-2 for JP6 configures the DK78113 for RS-232 serial operation.
		2-3 Installing a jumper at 2-3 for JP6 configures the DK78113 for RS-485 serial operation.

Figure 1-1 shows the user selectable jumper locations described in the table above as well the location of pin 1. Pin 1 is indicated as a square pin in the diagram, with subsequent pins counting up from there 2, 3, etc...



1.9.1 Enabling the Card

The MC78113 requires an active *Enable* signal to operate. To accomplish this the Amplifier Signal Connector (J9) is used. Connect terminal #1 of J9 (indicated on the card as ~EN) to terminal #3 of J9 (indicated on the card as GND) using a short wire. J9 provides convenient push-type connections, so no other hardware is needed to make this connection.

For reference the following table provides the pinouts of the J9 terminal block connector:

Setting & Description	Pin #	Description
Enable	1	Enable input. Must be tied low (GND) to enable the MC78113 for full operation.
FaultOut	2	Programmable FaultOut signal output.
GND	3	Digital ground

1.10 Connection Summary

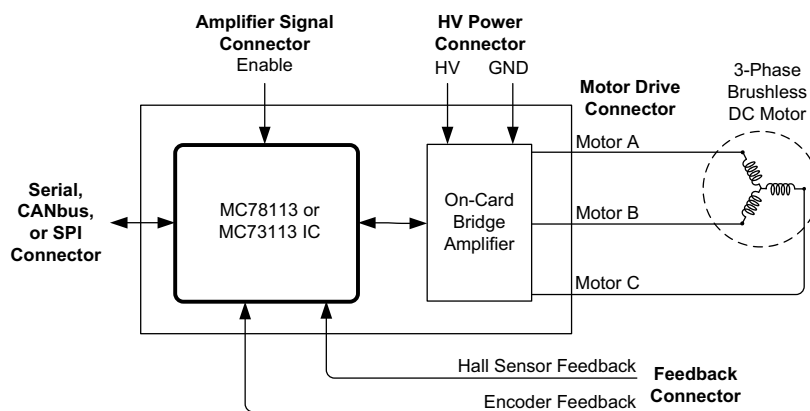

Figure 1-2: Brushless DC Motor Connection Overview

Figure 1-3:
DC Brush
Motor
Connection
Overview

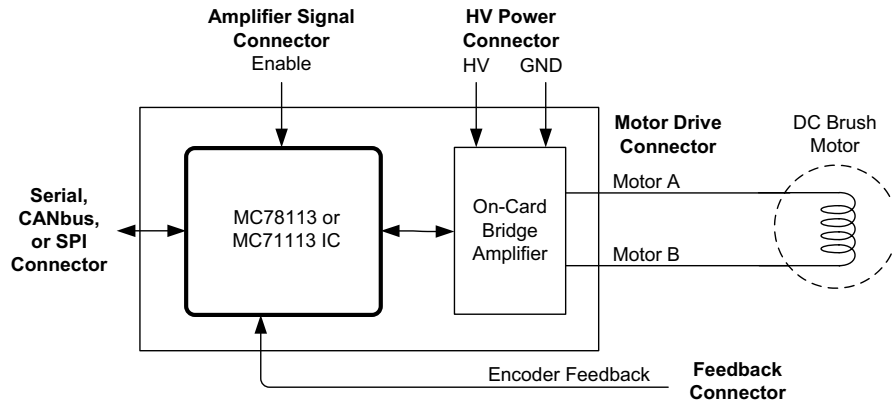
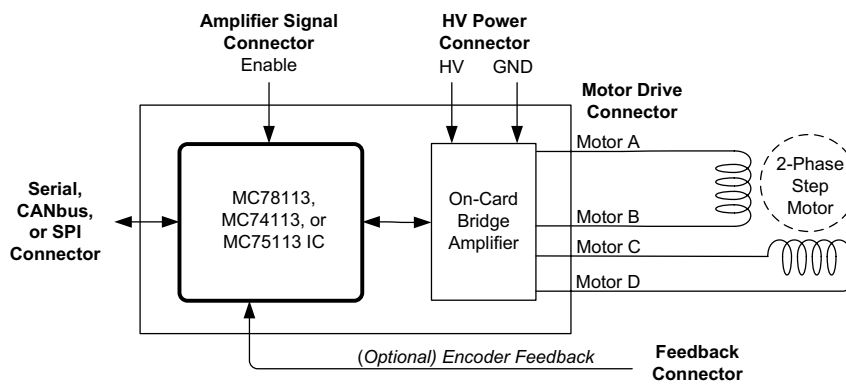

Figure 1-4:
Step Motor
Connection
Overview



Figures 1-2 through 1-4 provides general connection overviews for Brushless DC, DC Brush, and step motors. These diagrams do not show all possible connections or operational modes, but show the connections that may be used with this first-time installation of the DK78113.

You will need to connect signals on various connectors to properly install the DK78113 card with the attached motor. The following three sections detail how this should be done.

1.10.1 Axis Feedback Connections

The following table summarizes the *Axis* signal connections to the DK78113. All connections are made through the Axis Feedback Connector (J7), which is a high density female DB-15.

Pin #	Signal Name	Description
1	QuadA+	Differential A+ quadrature input. <i>optional for step motor axes</i>
2	QuadA-	Differential A- quadrature input. <i>optional for step motor axes</i>
3	QuadB+	Differential B+ quadrature input. <i>optional for step motor axes</i>
4	QuadB-	Differential B- quadrature input. <i>optional for step motor axes</i>
5	GND	This is the preferred ground connection for the quadrature and Index signal inputs
6	Index+	Differential Index+ quadrature input. <i>optional for step motor axes</i>
7	Index-	Differential Index- quadrature input. <i>optional for step motor axes</i>
8	HallA	Hall signal input phase A. <i>not used for DC Brush or step motors</i>
9	HallB	Hall signal input phase B. <i>not used for DC Brush or step motors</i>
10	HallC	Hall signal input phase C. <i>not used for DC Brush or step motors</i>
11-13	NC	No Connect

Pin #	Signal Name	Description
14	+5V	+5V power output which may be used to power the motor's encoder circuitry
15	NC	No Connect

1.10.1.1 Single-ended Encoder Connections

Encoder inputs may be connected differentially, with two wires per signal (as shown in the table above), or with just one wire per signal. If single-ended encoders are used, connect encoder signals to the positive encoder input only. The negative input may remain unconnected.

1.10.2 Motor Drive Connections

The following table summarizes the motor drive connections from the DK78113 to the motor. The motor drive connector, J6, is designed to connect to all available motor types: Brushless DC, DC Brush, and step motor. There are four motor drive connections and a shield connection. Not every motor type uses all four drive connections.

The J6 Motor Drive Connector is a Phoenix Contact 5-circuit terminal block connector.

Pin #	Signal Name	Description
1	MotorA	A motor drive lead. Used with all motor types.
2	MotorB	B motor drive lead. Used with all motor types
3	MotorC	C motor drive lead. Used with all motor types except DC Brush
4	MotorD	D motor drive lead. Use with step motors only
5	Case/shield	Connection to motor case/shield. A shield connection is strongly recommended for most motor setups

You may refer to [Figures 1-2](#) through [1-4](#) or use the table below to determine which leads should be connected for each supported motor type:

Motor Type	DK78113 Motor Lead	Motor Coil Connections
Brushless DC	MotorA	A winding connection
	MotorB	B winding connection
	MotorC	C winding connection
	Case/shield	(optional) motor shield connection
DC Brush	MotorA	+ winding connection
	MotorB	- winding connection
	Case/shield	(optional) motor shield connection
Step motor	MotorA	phase A+ winding connection
	MotorB	phase A- winding connection
	MotorC	phase B+ winding connection
	MotorD	phase B- winding connection
	Case/shield	(optional) shield connection

Shield connections to the motor are strongly recommended. Not connecting the shield signal may result in increased EMI (electromagnetic interference), reduced immunity to ESD (electro static discharge), or electrical noise resulting in motor operation failure.



1.10.3 Motor Power Connections

The following table summarizes the motor power connections from the DK78113 to your power supply via the J8 connector. This HV connection is also the power connection from which the card logic power is derived using an on-board DC-DC converter.

All connections are made through the Motor Power Connector, which is a Phoenix Contact 2-circuit terminal block connector.

Pin #	Signal Name	Description
1	HV	Positive motor voltage power
2	GND	Motor voltage power ground

The HV voltage should be the voltage at which the motor will be driven and must be in the range of 12V - 56V.

1.10.4 Communication Connections

While the DK78113 card can communicate using CANbus, SPI (Serial Peripheral Interface), and one of two serial modes (RS-232 and RS-485), in this first-time installation we will set up the card for serial RS-232 communications. To set up the card for operation in other communication modes, see Chapter 2, “Operation” and the *Pro-Motion User's Guide*.

A serial port accessory cable is included with the DK78113. This serial cable (PMD p/n Cable-1007-01) should be connected to the DK78113 card's J3 Serial Connector, while the opposite end of the serial cable should be connected to your computer's 9 pin serial port. If your computer does not have a dedicated serial port, the included USB to serial converter should be used.

1.11 Applying Power

Once you have made your motion hardware, communication, and power connections, hardware installation is complete and the card is ready for operation. When power is applied, the DK78113's green power LED should light. This LED is labeled D24 in [Figure 1-1](#). If the LED does not light, recheck connections.

After power up no motor output will be applied. Therefore the motors should remain stationary. If the motors move or jump, power down the card and check the motor and encoder connections. If anomalous behavior is still observed, call PMD or your PMD representative for assistance.

1.12 First-Time System Verification

The first time system verification procedure summarized below has two overall goals. The first is to connect the DK78113 card with the PC that is being used so that they are communicating properly, and the second is to initialize the axis and bring it under stable control capable of making controlled moves. While there are many additional capabilities that Pro-Motion and the DK78113 card provide, these steps will create a foundation for further successful exploration and development.

Here is a summary of the steps that will be used during first time system verification. Each of these steps will be described below in a separate manual section.

- 1 Initiate Pro-Motion and establish communication between the PC and the card using the serial communications link.

- 2 Run Pro-Motion's Axis wizard to initialize parameters such as encoder direction and safe servo parameters (if using a servo motor). **Important!** In addition to application specific parameters you will need to enter various on-card amplifier-related parameters during Axis Wizard setup to safely operate with the on-card amplifier. Refer to [Section 3.6, "DK78113 On-Card Amplifier Quick Reference"](#) of this manual for a list of these required settings.
- 3 Execute a simple velocity profile demonstrating that the axis is operating correctly and under stable control.

During this first time system setup you may find it useful to refer to other PMD manuals including the *Pro-Motion User's Guide* for complete information on the Pro-Motion application. You may also want to refer to the *Magellan Velocity & Torque Control IC User's Guide* to familiarize yourself with operation of the MC78113, or the *Juno MC78113 Electrical Specifications*.

1.12.1 Establishing Serial Communications

To establish serial communications:

- 1 Make sure the MC78113 card is powered and connected to the PC via its serial port.
- 2 Launch the Pro-Motion application.

When Pro-Motion is launched you will be prompted with an Interface selection window. A typical screen view when first launching Pro-Motion appears below.

The purpose of the Interface dialog box is to indicate to Pro-Motion how your DK78113 card is connected to the PC. It provides various selectable communication options such as PCI, serial, CANbus, Ethernet.

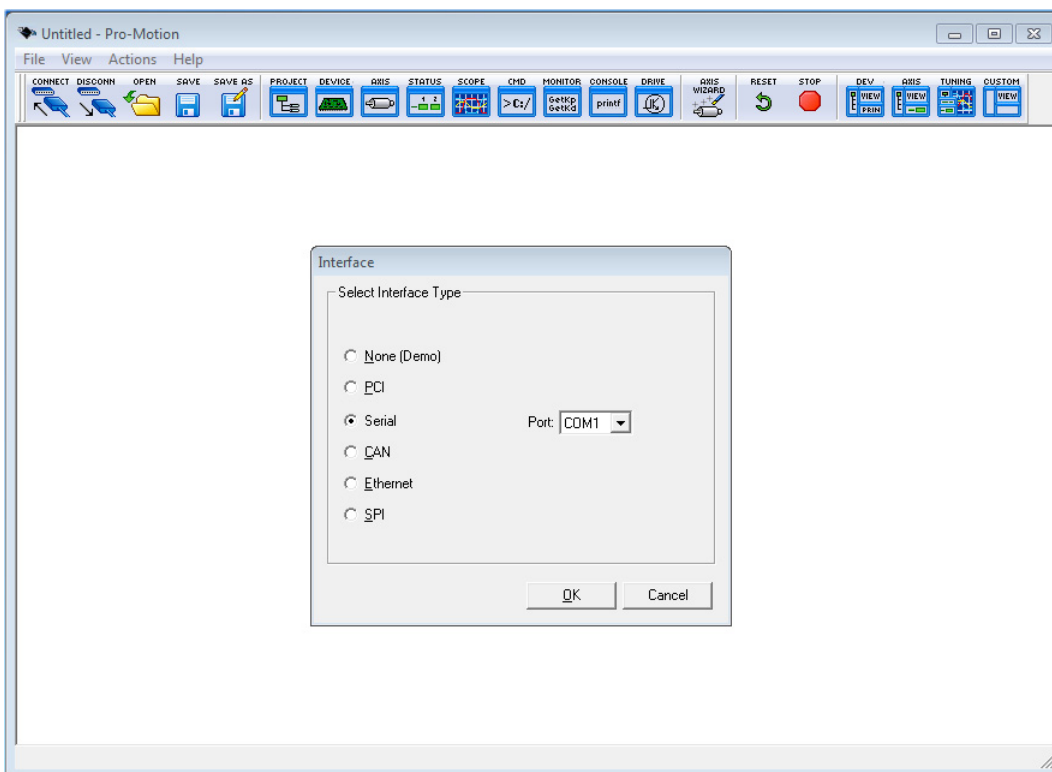

- 3 Click Serial, select the com port that the DK is connected to, and then click OK.

The Serial Port dialog box displays with default communication values of 57,600 baud, no parity, 1 stop bit, and point to point protocol.

- Click OK without changing any of these settings.

If serial communication is correctly established, a set of object graphics loads into the Project window to the left, as shown in the following figure.

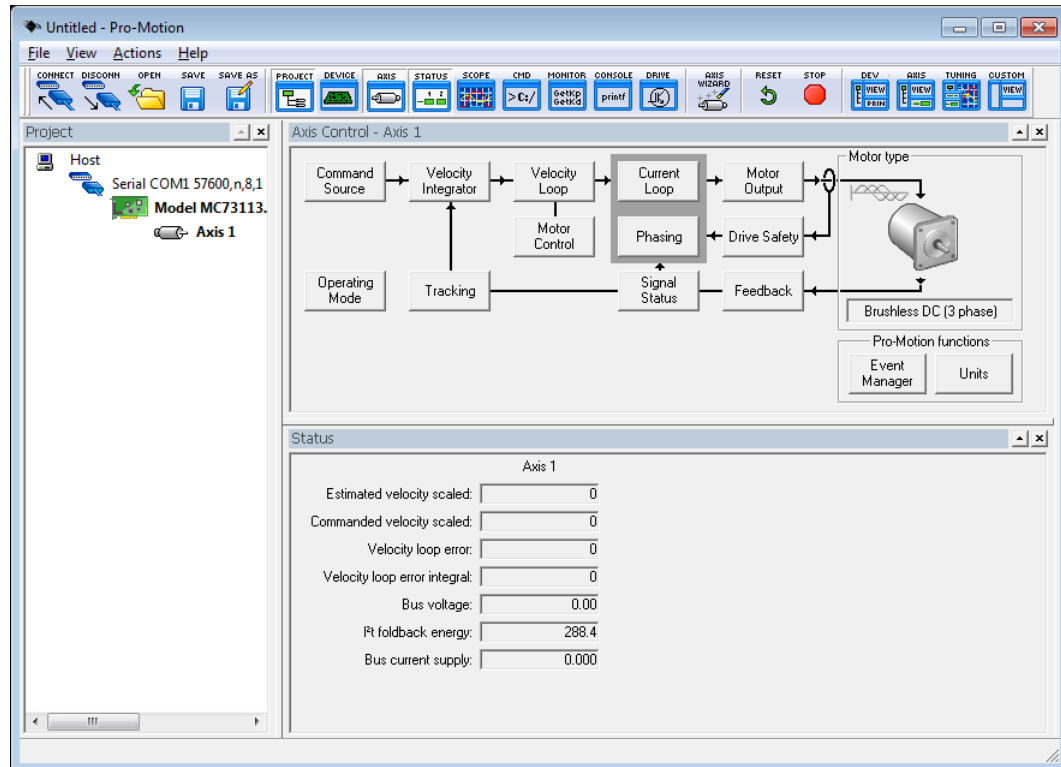

For example, you will see the MC78113 IC name next to an icon of a card, and below that you see an axis icon. Highlighting (single clicking) either the card icon or the axis icons with the mouse is used to select specific cards or axes, and is useful later on in the first time system verification.

If serial communications are not correctly established, a message appears indicating that an error has occurred. If this is the case, recheck your connections and repeat from step 1.

1.12.2 Initializing Motion Axis

The next step to verify the correct operation of the system is to initialize the axis, thereby verifying correct amplifier operation, encoder feedback connections (if an encoder is used), and other motion functions. All of this can be conveniently accomplished using Pro-Motion's Axis Wizard function. This versatile and easy to use tool initializes all supported motor types including step, DC brush, and brushless DC.

To operate the Axis Wizard:

- Select axis 1 to initialize in the Project window to the left of the screen.
- With this icon highlighted, click the Axis Wizard toolbar button.

The Axis Wizard initialization window appears.



- 3 Click Next and follow the Axis Wizard instructions for each page of the axis initialization process.

A typical Axis Wizard sequence takes 5-10 minutes. If you have specific questions about the Axis Wizard, refer to the *Pro-Motion User's Guide* for detailed information.

Important! In addition to application specific parameters you will need to enter various control parameters during Axis Wizard setup to safely control the card. Refer to [Section 3.6, "DK78113 On-Card Amplifier Quick Reference"](#) of this manual for a list of these required settings.

Upon a normal completion of the AxisWizard the axis will be ready to make a controlled move. For step motors this means the amplifier connections are working properly, and for servo motors this means the encoder and amplifiers connections have been validated, and stable (but not necessarily optimal, see caution below for more information) servo tuning parameters have been loaded into the card's MC78113 IC.

The most common reasons for the Axis Wizard to not complete normally are an inability to auto-tune the motor, or problems determining the correct commutation sequence for brushless DC motors. Should this happen, it is possible to perform a manual tuning or commutation setup if desired. Refer to the *Pro-Motion User's Guide* for more information, or call PMD or your local PMD representative for technical assistance.

The Axis Wizard auto tuning routines are designed to provide stable, but not optimal, parameters for motion. Pro-Motion provides a wealth of functions including a high speed hardware trace oscilloscope that can assist you in determining optimal parameters. Values provided by the Axis Wizard during auto tuning may or may not be safe for your system, and it is up to the user to determine if and when they should be used.

- 4 When completed, you will get to a screen called "Completing the Axis Wizard." Click Finish with the "Save settings to file" checkbox checked. You will now be prompted to specify a name of a project file. Choose a name that is convenient to you and select OK to store the configuration established during the Axis Wizard setup.

1.12.3 Performing a Simple Velocity Move

The last step in first time system verification is to perform a simple velocity move. To perform a simple move:

- 1 Click the Command Source button in the Axis Control window

The Command Source dialog box appears.

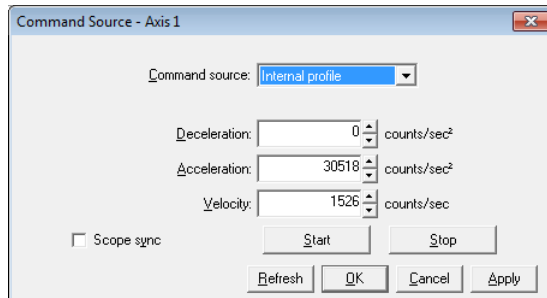

- 2 In the Command Source list, select Internal Profile.
- 3 Enter motion profiles for deceleration, acceleration, and velocity that are safe for your system and will demonstrate proper motion.



Pro-Motion provides various selectable units for distance and time, but defaults to units of encoder counts (or μ steps for step motors) for distance and seconds for time. This means the default units for velocity are counts/sec, and the default units for acceleration and deceleration are counts/sec². So for a motor that has 2,000 counts per rotation, to perform a symmetric trapezoidal move with a top speed of 5 rotations per second and with an acceleration time of two seconds, the parameters in the Command Source dialog box would be set as follows:

Deceleration: 5,000 counts/sec²

Acceleration: 5,000 counts/sec²

Velocity: 10,000 counts/sec

- 4 Click Go and confirm that the motion occurred in a stable and controlled fashion.
- 5 Click Stop to decelerate the motor to a velocity of zero.

Congratulations! First time system verification is now complete.

1.12.4 Restarting Pro-Motion

After first time verification is complete you may continue, in the same Pro-Motion session, to exercise your motion system or optimize control parameters as desired. Alternatively, whether immediately after additional interactions with Pro-Motion, you may wish to exit Pro-Motion for restart at a later time.

If you have changed additional control parameters and would like to save these parameters use File/Save Project As to save the current configuration to a file.

When restarting Pro-Motion it is important that you restore the configuration that you have saved, particularly the on-card amplifier limits and scale factors established during Axis Wizard setup. Do this by selecting File/Open Project, selecting the correct file previously stored.

Operation of the DK78113 without proper safety settings established during Axis Wizard operation may harm the DK78113 card or the application hardware. To avoid this be sure to restore saved control settings using the File/Open Project menu item before operating the DK78113 card.



This page intentionally left blank.

2. Operation

In This Chapter

- ▶ DK78113 Block Diagram
- ▶ Communication Ports
- ▶ Switching Motor Amplifier
- ▶ Drive Protection and Control Signals
- ▶ DC Bus
- ▶ Connecting to a Remote Amplifier
- ▶ Miscellaneous Signal Processing
- ▶ Pulse, Direction, & AtRest
- ▶ Analog Command & Tachometer Inputs
- ▶ Enable & FaultOut
- ▶ On-IC NVRAM Configuration Storage

2.1 DK78113 Block Diagram

The MC78113 Developer's Kit card (DK78113) provides a complete functioning MC78113-series IC exerciser and development system. It directly interfaces to a host computer using serial, CANBus, or SPI communication, and to all power and feedback signals required to drive a DC Brush, Brushless DC, or step motor.

The DK78113 incorporates several major subsystems including the MC78113-series IC itself, communications interface circuitry, a high performance MOSFET-based motor amplifier, a DC Bus conditioning system, and various other circuitry.

The following sections describe these major sections of the DK78113 card.

For a complete description of the MC78113 IC, see the *Juno Velocity & Torque Control IC User's Guide, MC78113 Electrical Specifications*, and the *Juno Velocity & Torque Control IC Command Reference*.

**Figure 2-1:
DK78113 Block
Diagram**

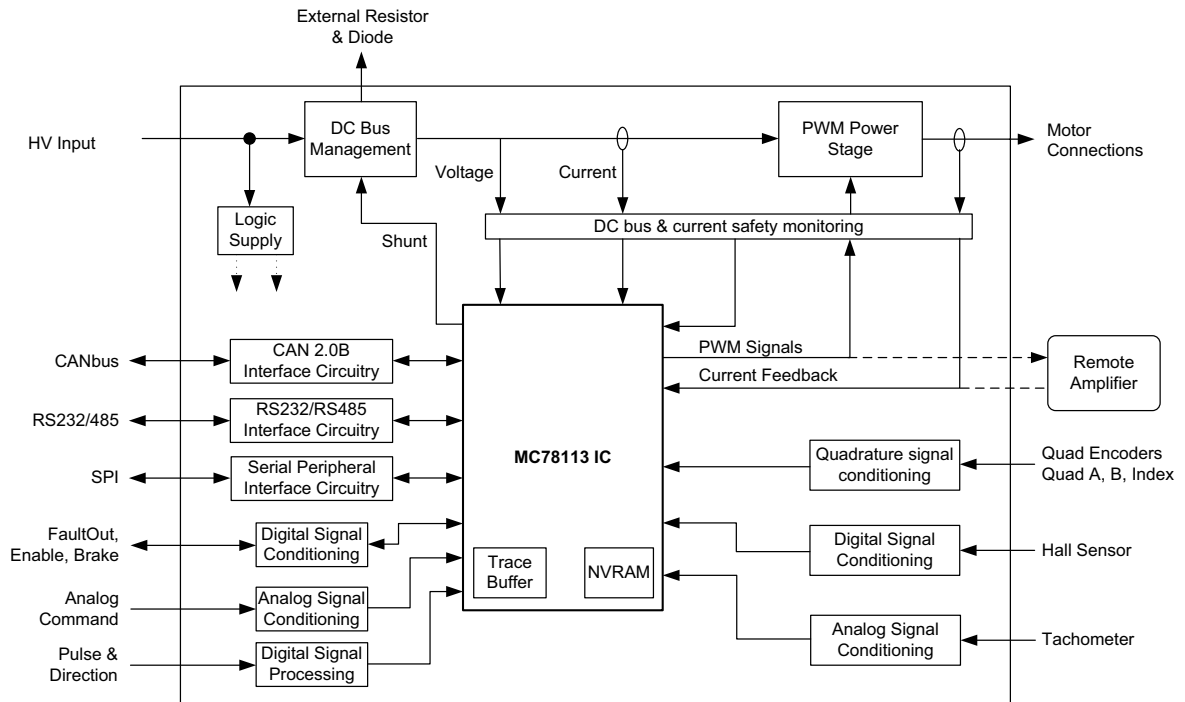

2.2 Communication Ports

2.2.1 RS-232/485

The DK78113 supports both the RS-232 and RS-485 signalling standard. Jumper JP6 is used to select between RS-232 and RS-485 operation. For RS-232, JP6 is connected at 1-2, and for RS-485 operation, JP6 is connected at 2-3.

The DK78113 supports point-to-point and multi-drop networking in RS-485, and point-to-point only in RS-232.

All DK78113 card communication functions are controlled by the MC78113 IC. For information on how to change serial port settings see the *Juno Velocity & Torque Control IC User's Guide*.

For RS-485 the DK78113 supports 4-wire full duplex operation.



The DK78113 does not have built-in termination for RS-485. If a network application requires termination at the serial connector, the resistors must be added in the network wiring:

2.2.2 CANbus

The DK78113 has a dual RJ45 connector (J13, J11) to allow daisy-chaining of MC78113s in a CANbus network. All pins in each port are connected to the corresponding pin in the other port. CAN_SHLD, CAN_V+ and the two Reserved pins are not used by DK78113 but are passed through from one port to the other. When the DK78113 module is the last node of a CANbus network, the network can be terminated by plugging a RJ45 terminator into the unused port.

Standard UTP (unshielded twisted pair) CAT5 Ethernet cabling can be used in most CAN applications. For added noise immunity, shielded cable can be used with the shield routed through the CAN_SHLD pins.

2.2.3 SPI (Serial Peripheral Interface)

The DK78113 supports an SPI (Serial Peripheral Interface) connection for host communications via its J2 connector.

The user may use this connector to directly communicate with the DK78113 from their own custom hardware design, or alternatively, communicate to the SPI port via a Windows-based PC. [Figure 2-2](#) shows this. While SPI is not recommended as a general inter-card interface, it may be useful in various circumstances such as to debug SPI-specific problems with a user-designed card.

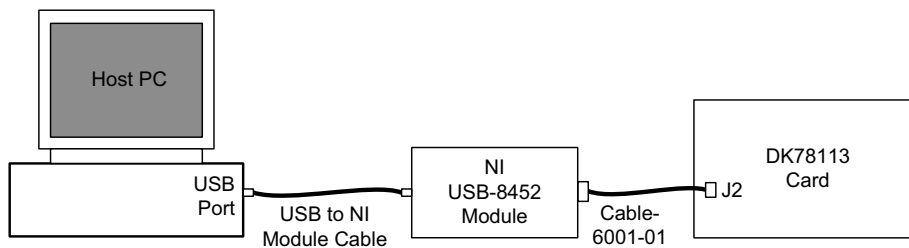

Figure 2-2:
PC to DK78113
SPI Connection
Summary

The major components required for PC to DK78113 SPI communications are listed below:

Item	Part Number	Manufacturer	Description
J2 to SPI interface module Cable	Cable-6001-01	PMD	This cable interconnects the National Instruments USB-8452 module to the DK78113's J2 connector
SPI interface module	NI USB-8452	National Instruments	This module generates SPI signals compatible with the MC78113's host SPI interface.
SPI interface module USB cable	NI USB-8452	National Instruments	This cable connects a USB port with the NI USB-8452 module. It is included with purchase of the USB-8452 module

Once these hardware items are installed PMD's Pro-Motion exerciser can be set for SPI communication mode, and thereafter will communicate to the DK78113 via the SPI interface. For more information on setting communication modes refer to the *Pro-Motion User's Guide*.

The special hardware items listed above, which are required for SPI communications between Pro-Motion and the DK78113 card, are not included with the standard DK78113. These items must be purchased separately from the indicated manufacturer.





Only the above-listed SPI interface module is supported by Pro-Motion. User-designed or other third-party SPI interface modules will not function correctly with Pro-Motion unless they are 100% compatible with the above listed SPI interface module.

If custom hardware is used to connect to the DK card's SPI port [Figure 2-3](#) shows representative processing circuits for the various SPI bus input circuitry.

Figure 2-3:
SPI Signal
Circuitry

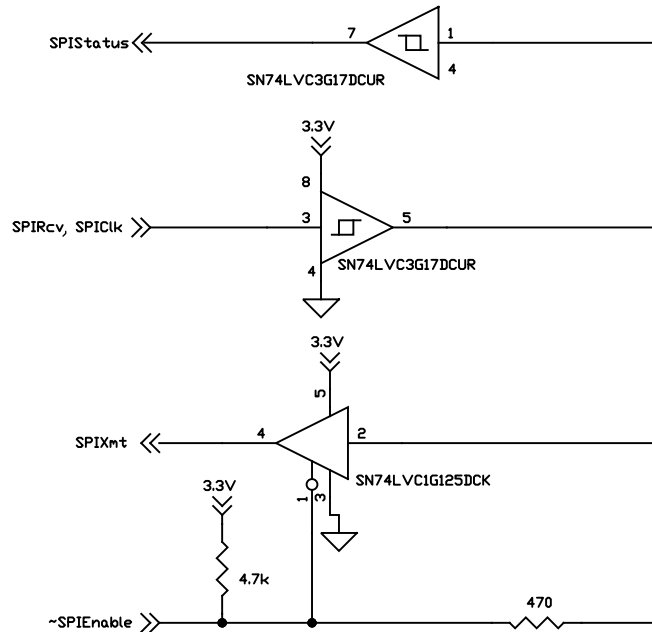

2.3 Switching Motor Amplifier

The DK78113 module contains a high-efficiency MOSFET power stage with PWM input control and leg current feedback. A different configuration is used for each motor type:

- Brushless DC motors are driven in a 3-phase bridge configuration consisting of 6 MOSFETs and 3 leg current sensors
- DC Brush motors are driven in an H-Bridge configuration consisting of 4 MOSFETs and 2 leg current sensors
- Step motors are driven with two H-Bridges, one for each phase, for a total of 8 MOSFETs and 4 leg current sensors

To operate the DK78113's on-card amplifier the JP4 and JP5 jumpers must be installed in the 1-2 position.

2.3.1 Brushless DC Motor Drive

[Figure 2-4](#) shows the arrangement of the DK78113's amplifier stage when the MC73113 IC is used or when the MC78113 IC is used with the Brushless DC motor type selected.

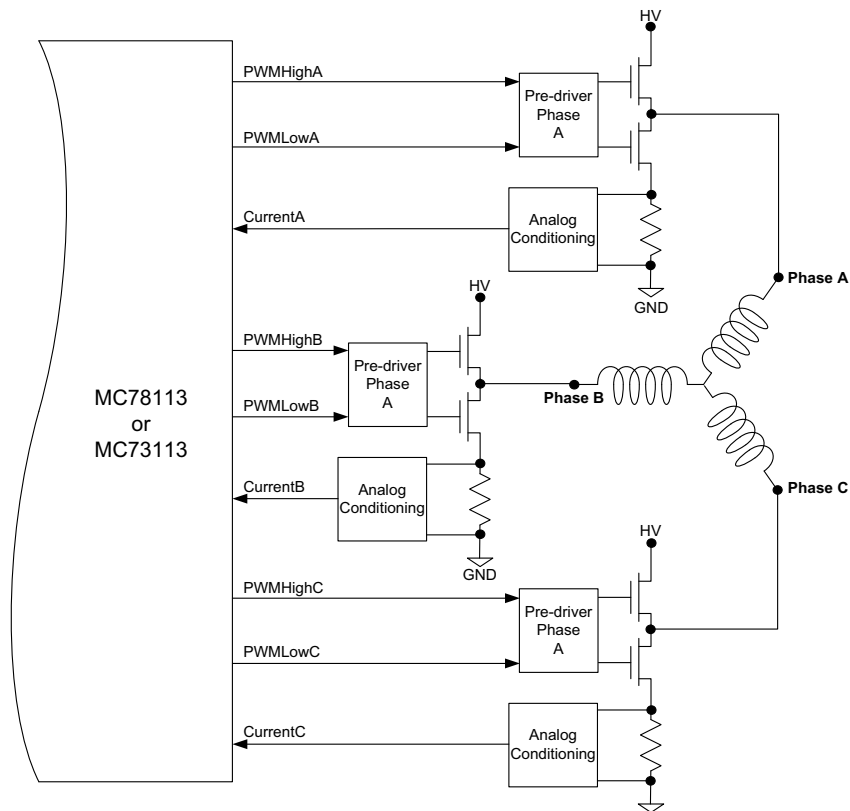

Figure 2-4:
Brushless DC
Motor Bridge
Configuration

As shown in the table below six PWM output signals and three analog feedback signals interface between the MC78113 IC and the DK78113's switching amplifier.

MC78113 Signal	Description
PWMHighA	Digital high side drive output for motor phase A
PWMLowA	Digital low side drive output for motor phase A
PWMHighB	Digital high side drive output for motor phase B
PWMLowB	Digital low side drive output for motor phase B
PWMHighC	Digital high side drive output for motor phase C
PWMLowC	Digital low side drive output for motor phase C
CurrentA	Analog input containing the current flow through the low side of the switching bridge for phase A.
CurrentB	Analog input containing the current flow through the low side of the switching bridge for phase B.
CurrentC	Analog input containing the current flow through the low side of the switching bridge for phase C.

2.3.2 DC Brush Motor Drive

[Figure 2-5](#) shows the arrangement of the DK78113's amplifier stage when the MC71113 IC is used, or when the MC78113 IC is used with the DC Brush motor type selected.

**Figure 2-5:
DC Brush
Motor Bridge
Configuration**

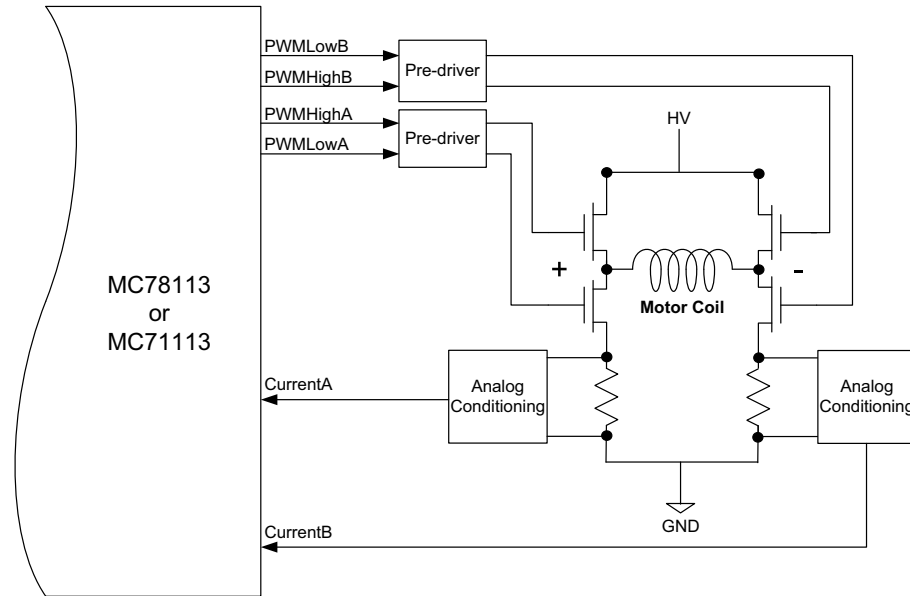

As shown in the table below four PWM output signals and two analog feedback signals interface between the MC78113 IC and the DK78113's switching amplifier.

MC78113 Signal	Description
PWMHighA	Digital high side drive output for positive coil terminal
PWMLowA	Digital low side drive output for positive coil terminal
PWMHighB	Digital high side drive output for negative coil terminal
PWMLowB	Digital low side drive output for negative coil terminal
CurrentA	Analog input containing the current flow through the positive leg of the bridge
CurrentB	Analog input containing the current flow through the negative leg of the bridge

2.3.3 Step Motor Drive

[Figure 2-6](#) shows the arrangement of the DK78113's amplifier stage when the MC74113 IC or MC75113 ICs are used, or when the MC78113 IC is used with the two-phase step motor type selected.

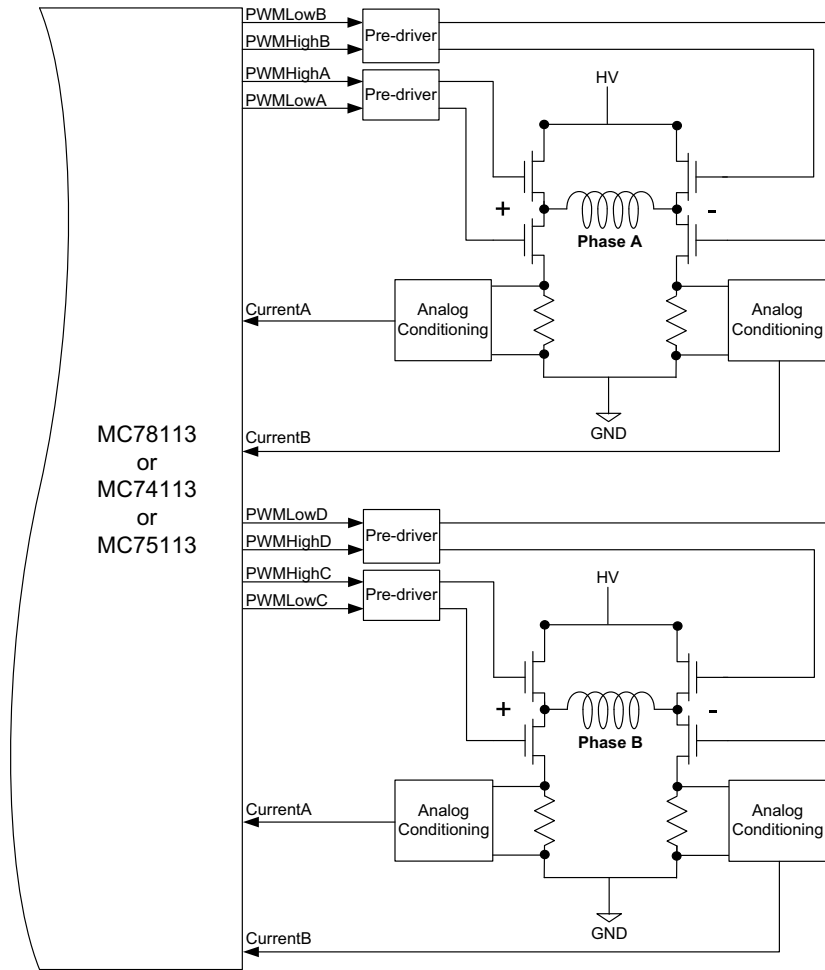

Figure 2-6:
Two-Phase
Step Motor
Bridge
Configuration

As shown in the table below eight PWM output signals and four analog feedback signals interface between the MC78113 IC and the DK78113's switching amplifier.

MC78113 Signal	Description
PWMHighA	Digital high side drive output for motor phase A, positive coil terminal
PWMLowA	Digital low side drive output for motor phase A, positive coil terminal
PWMHighB	Digital high side drive output for motor phase A, negative coil terminal
PWMLowB	Digital low side drive output for motor phase A, negative coil terminal
PWMHighC	Digital high side drive output for motor phase B, positive coil terminal
PWMLowC	Digital low side drive output for motor phase B, positive coil terminal
PWMHighD	Digital high side drive output for motor phase B, negative coil terminal
PWMLowD	Digital low side drive output for motor phase B, negative coil terminal
CurrentA	Analog input containing the current flow through the positive leg of phase A bridge
CurrentB	Analog input containing the current flow through the negative leg of phase A bridge
CurrentC	Analog input containing the current flow through the positive leg of phase B bridge
CurrentD	Analog input containing the current flow through the negative leg of phase B bridge

2.3.4 Amplifier-Related Settings

There are a number of MC78113 IC settings which are used to set or control various aspects of the DK78113's on-card switching amplifier and related current sense circuitry. If a remote amplifier (via the J4 connector) is connected the value of these settings will likely change.

The following table shows the default values and recommended (or required) settings for amplifier-related parameters:

Parameter	Value & Units	Comment
Motor Output Mode	PWM High/Low	Set the motor output mode to PWM High/Low for operation with the on-card amplifier. For remote amplifier operation PWM High/Low, 50/50 PWM, or sign/magnitude PWM may be selected.
PWM Switching Frequency	20 kHz	This setting is motor-specific. Higher inductance motors should be set for 20 kHz. Lower inductance motors may use 40, 80, or 120 kHz to reduce current ripple and minimize heat generation.
PWM Dead Time	540 nSec	For correct operation of the DK78113's on-card switching amplifier this parameter must be set to this value.
PWM Refresh Time	2,000 nSec	To ensure sufficient time to recharge the on-card amplifier's high side switches this parameter must be set to this value.
PWM Refresh Period	8 cycles	To ensure sufficient time to recharge the on-card amplifier's high side switches this parameter must be set to this value
PWM Signal Sense	Active High	For correct operation of the on-card amplifier all PWM outputs must be set to active high.
Minimum Current Read Time	2,000 nSec	To ensure sufficient minimum current read time with BLDC motors this parameter must be set to this value.



PWM High/Low motor output mode must be selected to use the DK78113's on-card amplifier. If any other motor output mode is selected the on-card amplifier must be disabled by installing JP4 and JP5 in the 2-3 position. See [Section 1.6, "Installation Overview"](#) for more information.

All of the MC78113 parameters described in this section can be conveniently specified using Pro-Motion via the Axis Wizard. See [Section 1.12, "First-Time System Verification"](#) for more information.

2.3.5 DK78113 Current Scale Value

To correctly control or trace motor current it is useful to know the DK78113's amplifier-specific current conversion factor. The following table shows this:

Parameter	Value & Units	Comments
Leg Current Conversion	.733 mA/count	This value should be entered so that the motor current can be traced and displayed correctly in amps.

All of the MC78113 parameters described in this section can be conveniently specified using Pro-Motion via the Axis Wizard. See [Section 1.12, "First-Time System Verification"](#) for more information.

2.4 Drive Protection and Control Signals

2.4.1 I²t Current Foldback Protection

The MC78113 uses current feedback to implement I²t current limiting. This feature protects the on-card amplifier by controlling its ability to operate above specific selected continuous current ratings.

When the current loop is enabled and the I²t energy limit is exceeded, the MC78113 will automatically fold back the phase currents to a user programmable continuous current limit value. Alternatively, the MC78113 can be configured to fault and disable the output stage when the I²t energy limit is exceeded.

See the *Juno Velocity & Torque Control IC User's Guide* for details.

2.4.1.1 I²t Limits

To safely operate the on-card DK78113 amplifier it is necessary to specify I²t limits.

Parameter	Value & Units	Comments
Brushless DC motor: Foldback Continuous Current Limit	5.0 A	This value should be entered to ensure the on-card amplifier does not operate above the maximum safe current output.
Brushless DC motor: Foldback Total Energy Limit	125 A ² sec	This value should be entered to ensure the on-card amplifier does not operate above the maximum safe current output.
DC Brush motor: Foldback Continuous DC Current Limit	5.0 A	This value should be entered to ensure the on-card amplifier does not operate above the maximum safe current output.
DC Brush motor: Foldback Total Energy Limit	125 A ² sec	This value should be entered to ensure the on-card amplifier does not operate above the maximum safe current output.
Step motor: Foldback Continuous Current Limit	5.0 A	This value should be entered to ensure the on-card amplifier does not operate above the maximum safe current output.
Step motor: Foldback Maximum Energy Limit	125 A ² sec	This value should be entered to ensure the on-card amplifier does not operate above the maximum safe current output.

For use with motors that have current and energy limits lower than those specified above, it may be useful to reduce these parameters.

These limits are designed to be safe for operation of the DK78113's on-card amplifier when cooled with a 110 CFM (or higher) fan and with an ambient room temperature of 25 degrees C. For use without a fan, or in higher ambient temperature environments, these values should be lowered.

If special heatsinking is used the DK78113 card is capable of driving motors at 7 amps continuously or higher, in which case these limits can be increased. Contact PMD for details.



If a remote amplifier (via the J4 connector) is used the value of these settings will likely change.

It is the responsibility of the user to set the Foldback Continuous Current and Foldback Energy Limit parameters to values that are safe for the DK78113 heat sinking scheme and motor setup being used.



All of the MC78113 parameters described in this section can be conveniently specified using Pro-Motion via the Axis Wizard. See [Section 1.12, “First-Time System Verification”](#) for more information.

2.4.2 Overtemperature Protection

The DK78113 uses a temperature sensor to continuously monitor the temperature of the on-card power MOSFETs.

2.4.2.1 Converting Temperature Readings into Degrees C

The MC78113 IC inputs temperature readings via its Temperature analog input and performs related functions such as over temperature checking without converting the readings from the attached temperature sensor into degrees C. It does this by comparing temperature in units of ‘counts,’ meaning the numerical value of the Temperature signal converted by the MC78113’s on-chip A/D.

While using Pro-Motion however, it is convenient to be able to view and trace the amplifier temperature in units of degrees C. This is accomplished by providing a conversion table to Pro-Motion.

Note that use of this table is optional and is only required if display of temperature via Pro-Motion is desired with units of degrees C. In any case, for the DK78113, the table “DK78113 Temp Table.txt” should be selected. See the *Pro-Motion Users Manual* for more information on how to select thermistor conversion tables.

2.4.2.2 Temperature Limit

The following temperature limit is required to safely operate the DK78113 card.

Parameter	Value & Units	Comments
Temperature limit	75.0 C	This value should be entered to ensure that the amplifier does not operate above the maximum safe temperature



The DK78113’s temperature sensor is located on the DK78113 card and therefore will not function correctly when a remote amplifier is used.

All of the MC78113 parameters described in this section can be conveniently specified using Pro-Motion via the Axis Wizard. See [Section 1.12, “First-Time System Verification”](#) for more information.

2.5 DC Bus

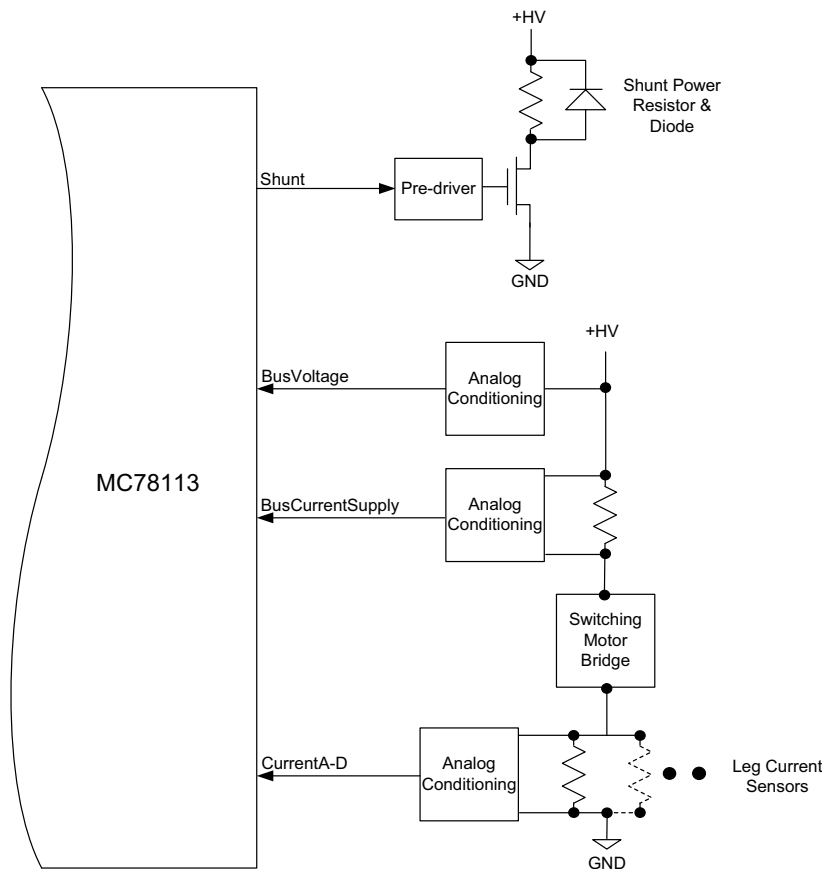

Figure 2-7:
DC Bus
Monitoring
Circuitry

[Figure 2-7](#) shows the DC bus monitoring circuitry used with the DK78113 board. This circuitry is designed to work with the MC78113’s DC bus management and protection logic. These functions include overcurrent protection, over and under voltage detection, ground fault detection, and shunt resistor control.

2.5.1 DC Bus Current Monitoring

DK78113 monitors both the positive and negative DC bus current to detect overcurrent conditions including: line-to-line, line-to-power supply, and line-to-ground short circuits.

2.5.1.1 DC Bus Current Monitoring Scale Values

The following DC bus current monitoring scale values for the DK78113 card are required to correctly operate the DC bus current monitoring functions:

Parameter	Value & Units	Comments
Bus current supply conversion	.505 mA/count	This value should be entered so that the DC bus current supply can be traced and displayed correctly in amps.
Leg current return conversion	.733 mA/count	This value should be entered so that the DC bus current return can be traced and displayed correctly in amps.

2.5.1.2 DC Bus Current Limits

The following MC78113 DC bus current limits are required to safely operate the DK78113 card:

Parameter	Value & Units	Comments
Bus Current Supply Limit	20.0 A	This value should be entered to ensure safe operation of the DK78113.
Bus Current Return Limit	20.0 A	This value should be entered to ensure safe operation of the DK78113.

Note that these values are designed to protect the DK78113 circuitry. Lower values may be used to protect the motor.



DC bus current monitoring functions will not work when a remote amplifier is used.

All of the MC78113 parameters described in this section can be conveniently specified using Pro-Motion via the Axis Wizard. See [Section 1.12, “First-Time System Verification”](#) for more information

2.5.2 DC Bus Voltage Monitoring

DK78113 monitors the main DC bus voltage for overvoltage and undervoltage conditions. These thresholds are user-settable within the voltage operating range of the drive.

DC bus voltage monitoring may operate even when a remote amplifier is used, as long as the +HV supply is still connected to the DK78113.

2.5.2.1 DC Bus Voltage Monitoring Scale Values

To correctly monitor the DK78113 DC bus voltage it is necessary to know the DC bus voltage scale factor. The following table provides this value.

Parameter	Value & Units	Comments
Bus Voltage Display	1.424 mV/count	This value should be entered so that the DC bus voltage can be traced and displayed correctly in volts.

2.5.2.2 DC Bus Voltage Limits

The following MC78113 DC bus voltage limits are required to safely operate the DK78113 card:

Parameter	Value & Units	Comments
Undervoltage Limit	10.0 V	This value should be entered to ensure safe operation of the DK78113.
Overvoltage Limit	60.0 V	This value should be entered to ensure safe operation of the DK78113.

Note that these values are designed to protect the DK78113 circuitry. More restrictive values may be used to protect the motor.

All of the MC78113 parameters described in this section can be conveniently specified using Pro-Motion via the Axis Wizard. See [Section 1.12, “First-Time System Verification”](#) for more information.

2.5.3 Shunt Resistor & Diode

J12 provides a connection for a shunt resistor and diode that may be used to regulate overvoltage conditions on the DC bus. Such conditions can occur during deceleration of a motor with a large inertia.

As shown in [Figure 2-7](#) the MC78113 provides a shunt PWM output, which in turn drives a MOSFET switch on the DK78113 card.

The resistor connected at J12 should have a resistance such that the current flow through the Shunt MOSFET does not exceed 10 amps. For example with an HV supply of 48 Volts, this means a resistance of no less than 4.8 ohms.

The diode, which is connected in parallel to the resistor, should have a voltage and current rating at least equal to those of the MOSFET. For the DK78113 this means a voltage and current rating of 100 volts and 10 amps or higher.

Beyond this limit, the actual resistance used is application specific and depends on the nature of the anticipated over voltage generating conditions, the power supply used, and the wattage rating of the resistor.

Example: a shunt resistor with a resistance of 10 ohms is connected through the J12 shunt connector and a comparison value of 51 Volts and a PWM duty cycle of 75% are specified. When the +HV voltage exceeds 51.0 Volts, HV will be connected to GND via the shunt resistor resulting in an effective average current flow of $(51.0V * .75) / 10 \text{ ohms} = 3.825 \text{ amps}$.

The default value of the shunt comparison mechanism is disabled. To enable, both a voltage comparison value and a PWM output duty cycle are specified. See the *Pro-Motion User's Manual* for details.

It is the responsibility of the user to connect and to specify a shunt-related resistor and diode that are safe for the application being controlled.



2.6 Connecting to a Remote Amplifier

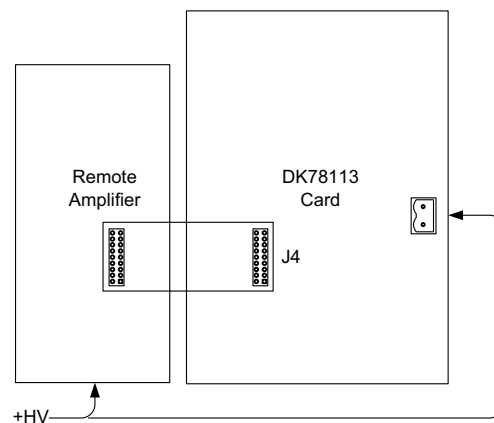

In addition to the DK78113's on-card switching amplifier, J4 provides connections for an external remote switching amplifier. This connector is typically used to interface with user-designed amplifiers that service higher power motors, or motor or actuators that require a special bridge configuration. Such an external amplifier connection is shown in [Figure 2-8](#).

Figure 2-8:
DK78113 to
Remote
Amplifier Card
Connections

**Figure 2-9:
Remote
Switcher
Circuits**

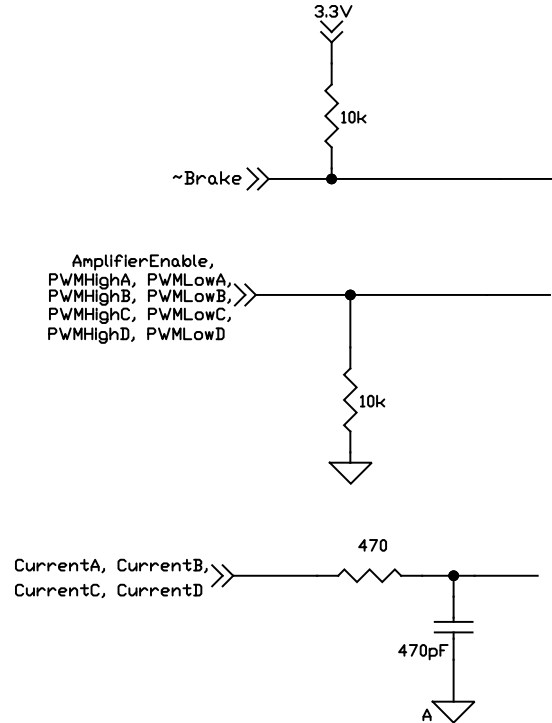

The DK78113's on-card amplifier must be disabled via JP4 and JP5 for remote amplifier operation. See [Section 1.6, "Installation Overview"](#) for details.

2.7 Miscellaneous Signal Processing

The following sections detail the signal processing circuitry provided by the DK78113 card for various signal connections.

2.7.1 Encoder Inputs

The MC78113's encoder input signals provide processing of quadrature encoder A, B feedback along with an Index signal. By default a valid index is recognized when Index is low however the interpretation of this signal as well as the A, B quadrature signals can be changed via the **SetSignalSense** command.

The differential input circuitry for the encoder A, B and Index signals is shown in [Figure 2-10](#). This circuit accepts both differential and single-ended signals in the range of 0 – 5 V. For single-ended operation, only the positive connection is used and the negative connection is left unconnected.

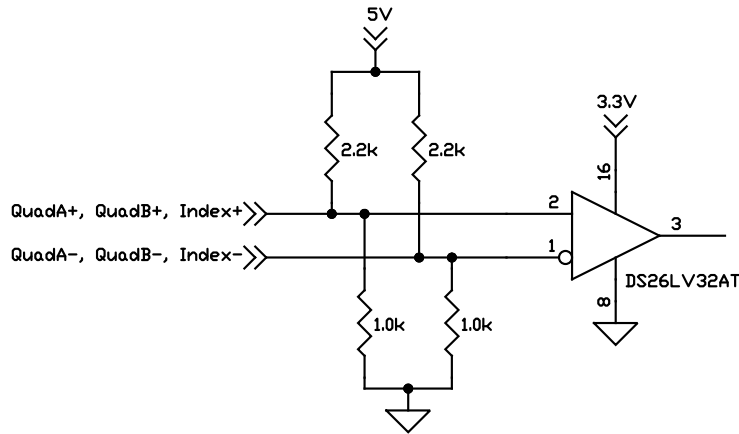

Figure 2-10: Main Encoder Input Circuits

2.7.2 Hall Inputs

Hall signals are used with Brushless DC motors. They are used to directly commutate the motor in 6-step commutation mode or to provide an absolute phase reference for sinusoidal commutation. By default Hall sensors are defined as being on when their signal is high however this can be changed via the command **SetSignalSense**.

The input buffer for the Hall A, B and C signals is shown in [Figure 2-11](#). This circuit accepts signals in the range of 0 – 24 V and has TTL compatible, Schmitt trigger thresholds. It has a pull-up to 5V to allow direct interfacing to open collector sources without the need for an external pull-up resistor and an R-C low pass filter to reject noise.

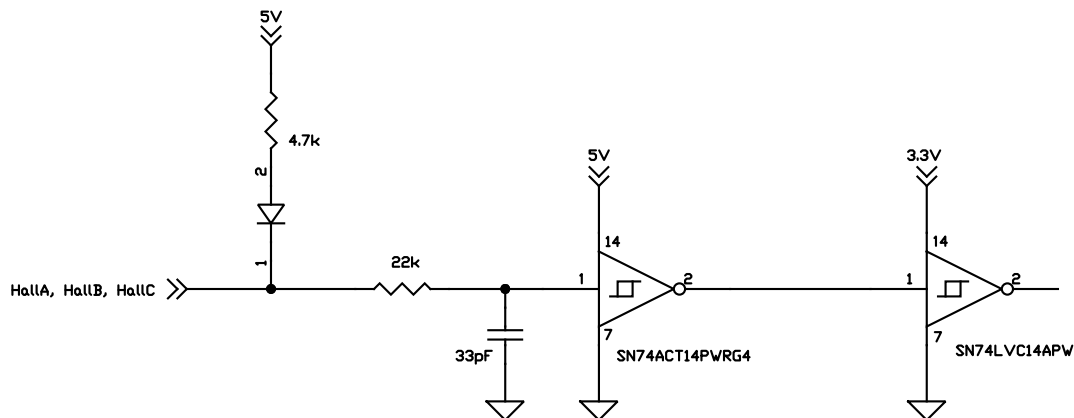

Figure 2-11: Hall Input Circuits

2.8 Pulse, Direction, & AtRest

Pulse & Direction are digital input signals that provide a continuous command position to the MC78113 IC. The **AtRest** signal, if used, indicates whether the active torque level should be used or the lower holding torque level. By default a step occurs when the Pulse signal transitions from high to low, a high level on the Direction signal indicates a move in the positive direction, and a high level on the **AtRest** signal indicates the axis is at rest. All of these default signal interpretations can be changed by the **SetSignalSense** command.

[Figure 2-12](#) shows the input processing provided by the DK card for Pulse, Direction and **AtRest** signals. For all of these signals the input range is up to 5.5V and is TTL compatible.

Figure 2-12:
Pulse,
Direction, &
AtRest

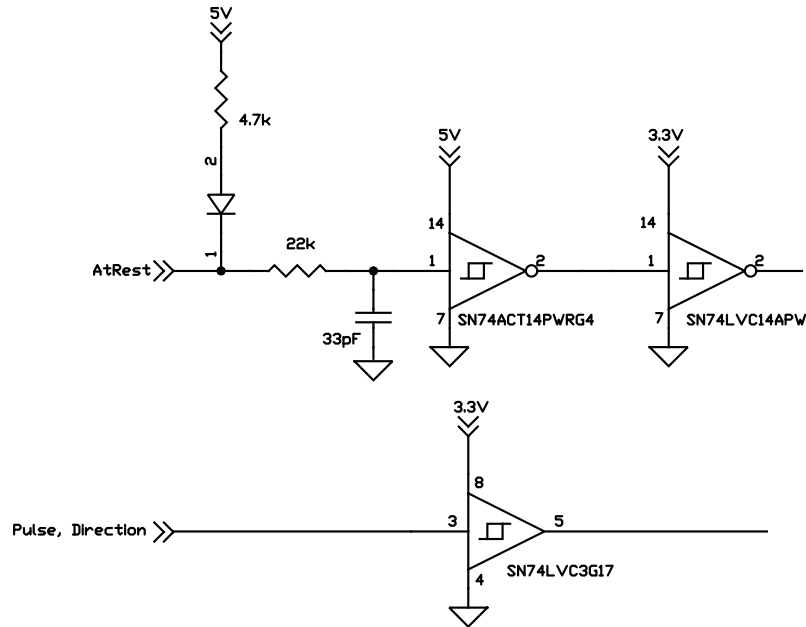

2.9 Analog Command & Tachometer Inputs

AnalogCmd is a differential +/-10V analog input that provides a direct torque or velocity command to the MC78113. The Tachometer signal, if used, is similarly encoded and provides analog velocity feedback to the MC78113.

The analog signal conditioning circuit for AnalogCmd and Tachometer is shown in [Figure 2-13](#). This circuit accepts +/-10V differential signal and scales it between 0 and 3.3V with an offset of 1.65V representing a zero input. The 680pF capacitors provide filtering with a bandwidth of 23.4kHz.

Figure 2-13:
Analog
Command &
Tachometer
Inputs

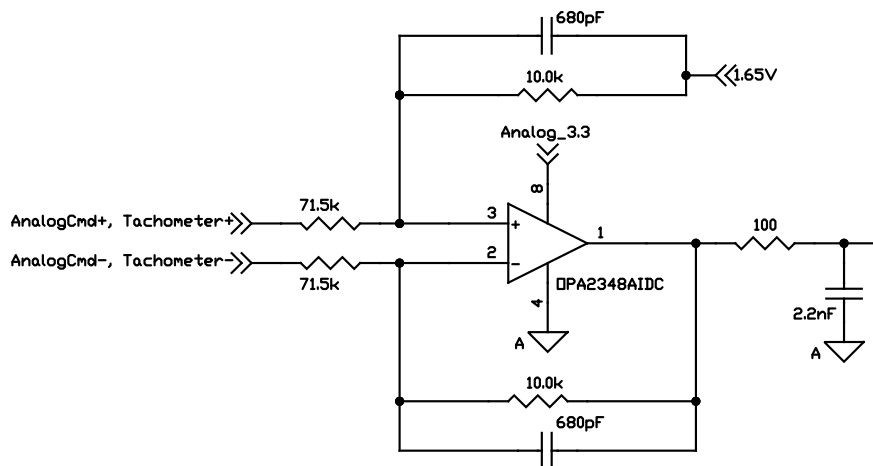

2.10 Enable & FaultOut

These dedicated signals are typically used to implement a safety interlock between the DK78113 card and other control portions of the system. /Enable is an active-low input that must be tied or driven low for the DK78113 output stage to be active.

FaultOut indicates a serious problem. When DK78113 is operating properly FaultOut is inactive. The polarity of these signals is fixed and cannot be changed via user command.

The input buffer for the /Enable input is shown in [Figure 2-14](#). This circuit accepts signals in the range of 0 – 24 V and has TTL compatible, Schmitt trigger thresholds. It has a pull-up to 5V to allow direct interfacing to open collector enable sources without the need for an external pull-up resistor and a 1.3 kHz R-C low pass filter to reject noise.

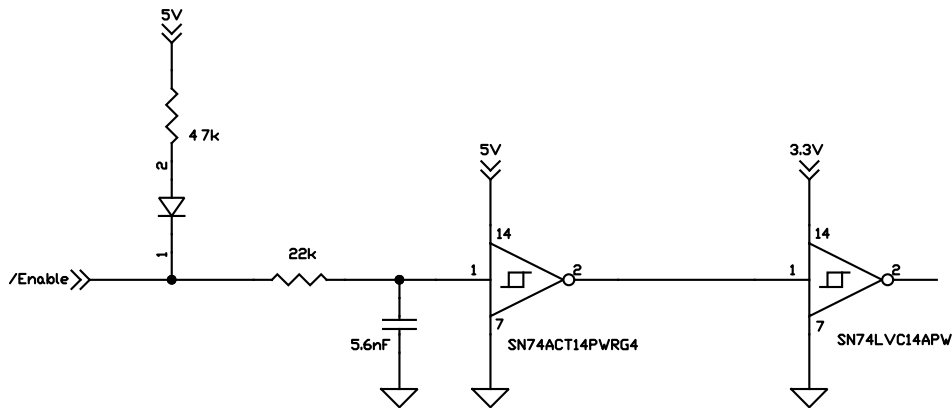

Figure 2-14:
Enable Input
Circuit

The output driver for FaultOut is shown in [Figure 2-15](#). This circuit can continuously sink over 100 mA and source 4mA from a pull-up resistor to 5V. The diode in series with the pull-up resistor allows loads powered from up to 24 VDC to be switched. The FET driver is internally protected from shorts up to 30 V.

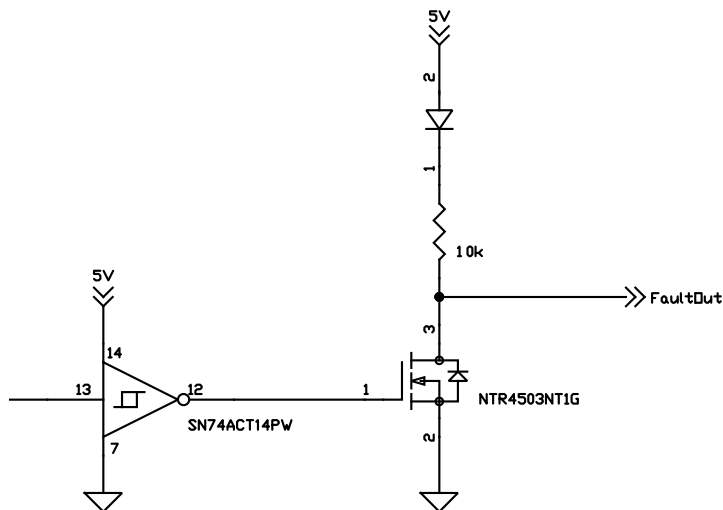

Figure 2-15:
FaultOut
Circuit

2.11 On-IC NVRAM Configuration Storage

The MC78113-series ICs provide the ability to directly store configuration information such as gain parameters, drive-related safety parameters, and other parameters. This setup information, once loaded, is automatically initialized into the MC78113's active configuration registers at each power-up. When used in an actual control system the NVRAM may therefore be useful to reduce or eliminate communications to the MC78113 IC during powerup. See the *Juno Velocity & Torque Control IC User's Guide* for more information on MC78113-series ICs powerup.

3. Electrical Reference

In This Chapter

- ▶ User-Settable Components
- ▶ Connectors
- ▶ Motor Connection Quick Reference
- ▶ Absolute Maximum Ratings
- ▶ Environmental and Electrical Ratings
- ▶ DK78113 On-Card Amplifier Quick Reference

3.1 User-Settable Components

The following table details the available DK78113 jumper settings, which are the DK78113's only user-settable hardware components:

Jumper ID	Factory Default Setting	Setting & Description
JP2	1-2	1-2 Installing jumper at 1-2 for JP2 configures the SPI port for host communications <i>utilizing the packet-based commands described in the Juno Velocity & Torque Control IC Command Reference.</i>
JP2		2-3 Installing jumper at 2-3 configures the SPI port for direct input velocity and torque commands.
JP4, JP5	1-2 (on-card amplifier)	1-2 Installing jumpers at 1-2 for JP4 and JP5 configures the DK78113 for operation of the on-card amplifier. 2-3 Installing jumpers at 2-3 for JP4 and JP5 disables the on-card amplifier, and configures the DK78113 for operation with a user-designed amplifier via the J4 Remote Amplifier Connector.
JP6	1-2 (RS-232)	1-2 Installing a jumper at 1-2 for JP6 configures the DK78113 for RS-232 serial operation. 2-3 Installing a jumper at 2-3 for JP6 configures the DK78113 for RS-485 serial operation.

3.2 Connectors

Figure 3-1:
DK78113 Card
Component
Location

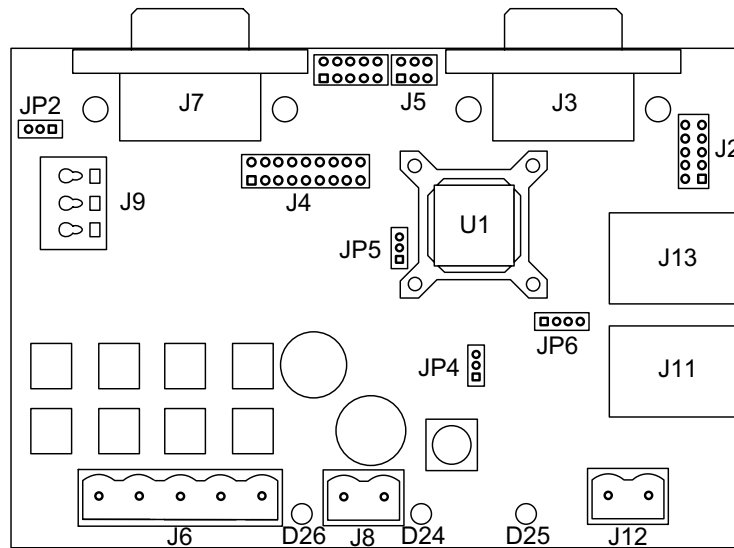

There are 14 user-accessible connectors on the DK78113 card. See [Figure 3-1](#) for the specific locations of the connectors on the card. The connectors and their functions are outlined in the following table:

Label	Description
J8	HV Power Connector
J6	Motor Drive Connector
J7	Feedback Connector
J9	Amplifier Signal Connector
J4	Remote Amplifier Connector
J5	Analog Command Connector
J12	Shunt Connector
J13, J11	CAN1, CAN2 Connectors (respectively)
J3	Serial Connector
J2	Host SPI Connector
D24, D25, D26	Power, fault, and amplifier enabled LED indicators (respectively)
JP2	SPI Mode jumper
JP4, JP5	Remote amplifier enable jumpers
JP6	RS-232/RS-485 selector jumper

3.2.1 HV Power Connector (J8)

The DK78113 card uses a dedicated 2-pin HV power connector (J8) that accepts input voltage in the range of +12 to 56 VDC. This connector is a Phoenix Contact 2-circuit pluggable terminal block connector.

Pin	Connection	Description
J8 - HV Power Connector		
1	HV	Provides DC power to the card and on-card switching amplifier
2	GND	Ground

3.2.2 Motor Drive Connector (J6)

The Motor Drive connector (J6) provide motor output signals for use with Brushless DC, DC Brush, or step motors. This is a Phoenix Contact 5-circuit pluggable terminal block connector.

Pin	Connection	Description
J6 - Motor Drive Connector		
1	Motor A	Motor output signal A
2	Motor B	Motor output signal B
3	Motor C	Motor output signal C
4	Motor D	Motor output signal D
5	GND	Ground

3.2.3 Feedback Connectors (J7)

The Feedback Connector (J7) provides connections to various motor feedback signals. The Feedback Connector uses a 15-pin high density DB connector, which can be connected to the PMD MC-HW-05 breakout board accessories.

3.2.3.1 Feedback Connector

Pin	Connection	Description
J7 - Feedback Connector		
1	QuadA+	Quadrature A+ encoder input
2	QuadA-	Quadrature A- encoder input
3	QuadB+	Quadrature B+ encoder input
4	QuadB-	Quadrature B- encoder input
5	GND	Ground
6	Index+	Index+ input
7	Index-	Index- input
8	HallA	Hall A input
9	HallB	Hall B input
10	HallC	Hall C input
11-13	NC	No Connect
14	Vcc	+5V output
15	NC	No Connect

3.2.3.2 Notes on Encoder Connections

Encoder inputs may be connected differentially, with two wires for QuadA, QuadB, and Index signals, or with just one wire per signal. If single-ended encoders are used, connect encoder signals to the positive encoder input only. The negative input may remain unconnected.

The following tables show this:

Encoder connections when using differential encoder input:

Signal	J7 Feedback Connector
QuadAn+	J7-1
QuadAn-	J7-2
QuadBn+	J7-3
QuadBn-	J7-4
Indexn+	J7-6
Indexn-	J7-7
Vcc	J7-14
GND	J7-5

Encoder connections when using single-ended encoder input:

Signal	J7 Feedback Connector
QuadAn	J7-1
QuadBn	J7-3
Indexn	J7-6
Vcc	J7-14
GND	J7-5

3.2.4 Amplifier Signal Connector (J9)

The Amplifier Signal Connector provides an Enable input to the MC78113 IC as well as the FaultOut from the MC78113. This connector provides convenient jack screw access to these signals, making it easy to (for example) connect the GND signal to the Enable signal with a short wire.

Pin	Signal	Description
J9 - Amplifier Signal Connector		
1	Enable	Active low Enable digital input signal
2	FaultOut	Active high digital FaultOut output signal
3	GND	Ground

3.2.5 Remote Amplifier Connector (J4)

This connector provides signals that allow an external switching amplifier to be connected to the DK78113. This connector is not used if the on-card amplifier is used. J4 is a 16-pin 0.1 inch dual-row header (P/N Samtec TSW-108-07-G-D).

If a remote amplifier is used jumpers JP1 and JP2 must be set to the 2-3 position. In addition, it is not necessary to provide HV power to the card, only +5V via J2 is required.

Pin	Signal	Description
J4 - Remote Amplifier Connector		
1	AmplifierEnable	AmplifierEnable output signal from MC78113
2	Brake	Brake input signal to MC78113
3	PWMHighA	PWMHighA output signal from MC78113
4	PWMLowA	PWMLowA output signal from MC78113

Pin	Signal	Description
5	PWMHighB	PWMHighB output signal from MC78113
6	PWMLowB	PWMLowB output signal from MC78113
7	PWMHighC	PWMHighC output signal from MC78113
8	PWMLowC	PWMLowC output signal from MC78113
9	PWMHighD	PWMHighD output signal from MC78113
10	PWMLowD	PWMLowD output signal from MC78113
11	GND	Ground
12	AGND	Analog Ground
13	CurrentA	CurrentA analog input signal to MC78113
14	CurrentB	CurrentB analog input signal to MC78113
15	CurrentC	CurrentC analog input signal to MC78113
16	CurrentD	CurrentD analog input signal to MC78113

3.2.6 Shunt Connector (J12)

The DK78113 card uses a dedicated high current 2-pin connector for connection to a shunt resistor or similarly functioning component in applications where it may be desirable to remove excess voltage from the DC bus.

This connector is a Phoenix Contact 2-circuit pluggable terminal block.

Pin	Signal	Description
J12 - Shunt Connector		
1	HV	+HV
2	Shunt	Switched connection to ground

3.2.7 Analog Command Connector (J5)

The Analog Command Connector (J5) provides differential +/-10V analog commands and tachometer feedback inputs. This connector is a 6-pin 0.1 inch dual-row header (P/N Samtec TSW-103-07-G-D).

Pin	Signal	Description
J5 - Analog Command Connector		
1	AnalogCmd+	Command+ input
2	Tachomter+	Tachometer+ input
3	AnalogCmd-	Command- input
4	Tachomter-	Tachometer- input
5	AGND	Analog Ground
6	AGND	Analog Ground

3.2.8 CAN Connectors (J13, J11)

The DK78113's controller are a network (CAN) transceivers are designed for use in applications employing the CAN serial communication physical layer in accordance with the ISO11898 standard. The transceiver provides differential transmit and differential receive capability to/from a CAN controller at speeds up to 1 Mbps.

There are two connectors, J13, and J11, providing electrically identical signals. These two connectors are designed to make it easy to connect the DK78113 card in a daisy-chain configuration. Termination at each end of the cable run is generally recommended unless cable lengths are very short and speed is slow. ISO-11898 requires 120 Ohm termination at each end of the bus. Note that it is up to the customer to verify their network topology and operating parameters.

The CANbus connector is a female RJ45 type connector.

See [Section 2.7.1, “Encoder Inputs”](#) for more information on the functionality of the CANbus port.

The pinouts for both the J13 and J11 CAN connector are as follows:

Pin	Signal	Description
J13, J11 - CANbus Connectors		
1	CAN+	Positive CAN signal connection
2	CAN-	Negative CAN signal connection
3	GND	Ground
4	No Connect	Pass-through signal
5	No Connect	Pass-through signal
6	No Connect	Pass-through signal
7	GND	Ground
8	No Connect	Pass-through signal

3.2.9 Serial Connector (J3)

The Serial Connector (J3) provides connections to an RS-232 or RS-485 serial port. Electrically these connectors provide access to the same signals, however they have different physical connectors and wiring. The following sections provide information for the serial connector, and provide pinouts when operated in RS-232 mode or RS-485 full-duplex mode.

J3 is a standard 9-pin female D-sub connector.

Pin	Connection	RS-232	RS-485 Full Duplex
J5 - Serial Connector			
1	NC	No Connect	No Connect
2	SrIXmt	Serial transmit output	No Connect
3	SrIRcv	Serial receive input	No Connect
4	NC	No Connect	No Connect
5	GND	Ground	Ground
6	RS-485Rcv+	No Connect	Positive (non-inverting) receive input
7	RS-485Rcv-	No Connect	Negative (inverting) receive input
8	RS-485Xmt+	No Connect	Positive (non-inverting) transmit output
9	RS-485Xmt-	No Connect	Negative (inverting) transmit output

3.2.10 Host SPI Connector (J2)

This connector provides host SPI (Serial Peripheral Interface) signals when the MC78113's SPI host communication is used. This connector is an unshrouded 10-position double-row male header, .1" spacing.

Pin	Signal	Description
J2 - Host SPI Connector		
1	SPIXmt	SPI bus synchronous transmit signal from MC78113
2	SPIRcv	SPI bus synchronous receive signal to MC78113
3	SPIClock	SPI bus synchronous clock input
4	SPIEnable	Host SPI bus active low enable signal input
5	HostInterrupt	Host interrupt output from MC78113 can be programmed to indicate an event requiring attention from the host
6	SPIStatus	This signal indicates when an SPI response is available.

Pin	Signal	Description
7	GND	Ground
8	Reset	Active low reset signal for MC78113 IC.
9	AtRest	At Rest input signal in Pulse & Direction mode
10	No Connect	

3.2.11 Connector Parts Reference

The following table is supplied as a reference only.

Label	Connector Name	Connector Part Number	Connector Mate
J8	HV Power	Phoenix Contact 2-circuit pluggable terminal block p/n 1924305	Phoenix Contact 2-circuit mating terminal, 5.08mm pitch. p/n 1912401
J6	Motor Drive	Phoenix Contact 5-circuit pluggable terminal block p/n 1924334	Phoenix Contact 5-circuit mating terminal, 5.08mm pitch. p/n 1912430
J7	Feedback	High density D-sub 15-position, female	High density D-sub 15-position, male
J9	Amplifier Signal	Phoenix Contact 3-circuit pluggable terminal block/p/n 1985205	N/A
J4	Remote Amplifier	2 by 8 un-shrouded header, male, .1" spacing	Samtec socket, 16-position, .1" spacing. p/n: ISDM-08
J12	Shunt	Phoenix Contact 2-circuit pluggable terminal block, p/n 1924305	Phoenix Contact 2-circuit mating terminal, 5.08mm pitch. p/n 1912401
J13, J11	CAN1, CAN2	RJ45	RJ45 connector plug
J3	Serial	DB-9, female	DB-9, male
J2	Host SPI	2 by 4 unshrouded header, male, .1" spacing	Samtec socket, 8-position, .1" spacing. p/n: ISDM-05

3.3 Motor Connection Quick Reference

The following sections show typical motor connection names and the associated DK78113 connector and pin numbers.

3.3.1 Brushless DC Motor Connections

Connection Name	DK78113 Pin
Motor A	J6-1
Motor B	J6-2
Motor C	J6-3
Case/Shield	J6-5

3.3.2 DC Brush Motor Connections

Connection Name	DK78113 Pin
Motor+	J6-1
Motor-	J6-2
Case/Shield	J6-5

3.3.3 Step Motor Connections

Connection Name	DK78113 Pin
Motor A+	J6-1
Motor A-	J6-2
Motor B+	J6-3
Motor B-	J6-4
Case/Shield	J6-5

3.4 Absolute Maximum Ratings

HV voltage range:	0V to +60V
+5V voltage range:	-0.3V to +5.5V

3.5 Environmental and Electrical Ratings

Storage temperature:	-40 to +125 degrees C (-40° F to +257°F)
Operating temperature:	0 to +70 degrees C (32° F to +158°F)
HV power requirement:	+12V to + 56V operating range
Motor amplifier continuous current limit*:	5.0 A
Motor amplifier peak current limit:	10.0 A
Optional +5V requirement:	4.75V to 5.25V DC operating range
Digital input voltage range:	0V to 5V, TTL thresholds
CAN communications:	2.0B compliant, non-isolated, 1 Mbps
Serial communications:	RS-232 signaling or RS-485 Full or Half Duplex (data only)

* Current rating at 25 C ambient and with 110 CFM air flow on card. Significantly higher currents are possible with additional heat sinking. Contact your PMD representative for details.

3.6 DK78113 On-Card Amplifier Quick Reference

The DK78113 comes with a standard MC78113 IC, and is thus not tailored for the amplifier and safety-related circuitry located on the DK78113 card. Therefore to use the MC78113/DK78113 circuitry safely and to view results conveniently via Pro-Motion you will need to set various limits and conversion constants.

These parameters are generally entered when using Pro-Motion's Axis Wizard setup sequence, however they are also useful if you decide to write your own software that operates the DK78113 card.

Parameter	Value & Units	Comments
Motor Output Mode	PWM High/Low	Set the motor output mode to PWM High/Low for operation with the on-card amplifier. For remote amplifier control operation PWM High/Low, 50/50 PWM, or sign/magnitude PWM may be selected.

Parameter	Value & Units	Comments
PWM Switching Frequency	20 kHz	This setting is motor-specific. Larger motors (some NEMA 23 and most NEMA 34) should be set for 20 kHz. Smaller motors may use 40, 80, or 120 kHz to maximize current control accuracy and minimize heat generation.
PWM Dead Time	540 nsec	For correct operation of the DK78113's on-card switching amplifier this parameter must be set to this value.
PWM Refresh Time	2,000 nSec	To ensure sufficient time to recharge the on-card amplifier's high side switches this parameter must be set to this value.
PWM Refresh Period	8 cycles	To ensure sufficient time to recharge the on-card amplifier's high side switches this parameter must be set to this value
PWM Signal Sense	Active High	For correct operation of the on-card amplifier all PWM outputs must be set to active high.
Minimum Current Read Time	2,000 nSec	To ensure sufficient minimum current read time with BLDC motors this parameter must be set to this value.
Leg Current Conversion	.733 mA/count	This value should be entered so that the leg current can be traced and displayed correctly in amps.
Brushless DC Motor: Foldback Continuous Current Limit	5.0 A	This value should be entered to ensure the on-card amplifier does not operate above the maximum safe current output.
Brushless DC Motor: Foldback Total Energy Limit	125 A ² sec	This value should be entered to ensure the on-card amplifier does not operate above the maximum safe current output.
DC Brush Motor: Foldback Continuous DC Current Limit	5.0 A	This value should be entered to ensure the on-card amplifier does not operate above the maximum safe current output.
DC Brush Motor: Foldback Total Energy Limit	125 A ² sec	This value should be entered to ensure the on-card amplifier does not operate above the maximum safe current output.
Step Motor: Foldback Continuous Current Limit	5.0 A	This value should be entered to ensure the on-card amplifier does not operate above the maximum safe current output.
Step Motor: Foldback Maximum Energy Limit	125 A ² sec	This value should be entered to ensure the on-card amplifier does not operate above the maximum safe current output.
Temperature Limit	75.0 C	This value should be entered to ensure the on-card amplifier does not operate above the maximum safe current output.
Bus Current Supply Conversion	.505 mA/count	This value should be entered so that the DC bus current supply can be traced and displayed correctly in amps.
Bus Current Supply Limit	20.0 A	This value should be entered to ensure safe operation of the DK78113.
Bus Current Return Limit	20.0 A	This value should be entered to ensure safe operation of the DK78113.
Bus Voltage Display	1.424 mV/count	This value should be entered so that the DC bus voltage can be traced and displayed correctly in volts.
Undervoltage Limit	10.0 V	This value should be entered to ensure safe operation of the DK78113.
Overvoltage Limit	60.0 V	This value should be entered to ensure safe operation of the DK78113.

This page intentionally left blank.